

Date of Installation : \_\_\_\_\_

Unit Serial Number : \_\_\_\_\_

Kompac Dealer : \_\_\_\_\_

**PRINTERS PARTS**  
800-543-1117 201-935-9595  
fax 800-392-4072 201-935-5333  
[www.ppsnj.com](http://www.ppsnj.com)

# Kompac®

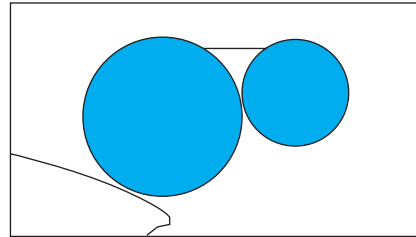

A DIVISION OF DAY INTERNATIONAL, INC.



DAY INTERNATIONAL, INC.

Image Transfer Group



## **RYB-334-KM**

Parts Catalog # 092362

AB DICK 9995, 9995A, 4995, 4995A  
RYOBI 3302H, 3302HA, 3304H, 3304HA

**PRINTERS PARTS**  
800-543-1117 201-935-9595  
fax 800-392-4072 201-935-5333  
[www.ppsnj.com](http://www.ppsnj.com)

**PRINTERS PARTS**  
 800-543-1117 201-935-9595  
 fax 800-392-4072 201-935-5333  
 www.ppsnj.com

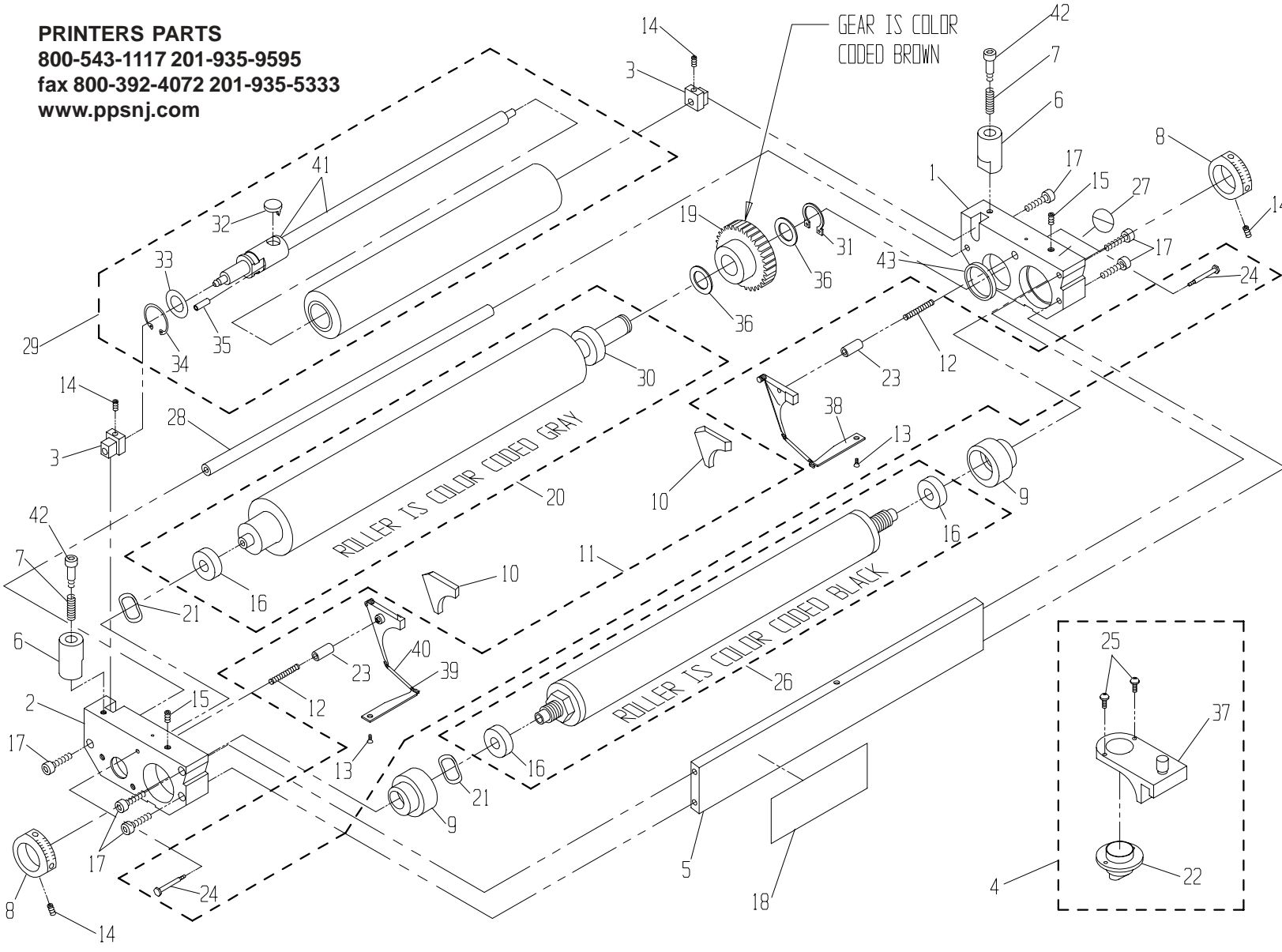

\* PART IS INCLUDED IN OUTLINED SUBASSEMBLY.

43	094097	SPACER, FORM ROLLER	1
42	091708	SHOULDER SCREW, 6mm	2
41	091262	SHAFT ASSY, S.S.	*
40	092259	SPRING COVER	*
39	092236	TAB SPRING	*
38	090971	TAB, SHORT	*
37	094997	BRACKET, NOZZLE	*
36	091966	WASHER, FLAT	2
35	091949	SPRING PIN	*
34	091997	OSC. RETAINING CLIP	*
33	091965	OSC. RETAINING WASHER	*
32	091111	OSC. DRIVE SHAFT FOLLOWER	*
31	091662	RETAINING RING	1
30	092586	BEARING	*
29	091319	13-1/4 OSC. ROLL. HARD SHELL	1
ITEM#	PART #	DESCRIPTION	QTY

28	090989	TIE ROD	1
27	092601	SAFETY STICKER	1
26	094240	13-1/4" METERING ROLLER W/B	1
25	091907	#6-32 X 3/8 PHILLIPS HD SCW	*
24	092296	SHOULDER SCREW	*
23	092304	GUIDE PIN	*
22	092604	NOZZLE	*
21	092491	WAVE WASHER	2
20	091900	13-1/4" FORM ROLLER W/B	1
19	092880	GEAR CLUTCH ASSY	1
18	090984	I.D. STICKER (HAMADA)	1
17	091898	M5 x 35mm SOC. HD. SCREW	6
16	092401	BEARING	*
15	091904	M5 x 16mm SET SCREW	2
ITEM#	PART #	DESCRIPTION	QTY

14	091888	M5 x 5mm SET SCREW	4
13	091901	M3 x 6mm SOC HD SCREW	*
12	092238	COMPRESSION SPRING	*
11	090970	BACKING PLATE KIT (HAMADA)	1
10	092370	SEAL SET (L & R)	1
9	092291	ECCENTRIC	2
8	092612	METERING GAUGE	2
7	092007	SPRING, COMPRESSION	2
6	094991	OSCILLATOR POST	2
5	090979	TIE BAR	1
4	098750	BRACKET NOZZLE ASSEMBLY	1
3	090985	ALIGNMENT BLOCK	2
2	090993	L.H. END FRAME	1
1	090994	R.H. END FRAME	1
ITEM#	PART #	DESCRIPTION	QTY

# RYB 334 BRACKET KIT; PART # 092376

# PARTS CATALOG # 092362-A

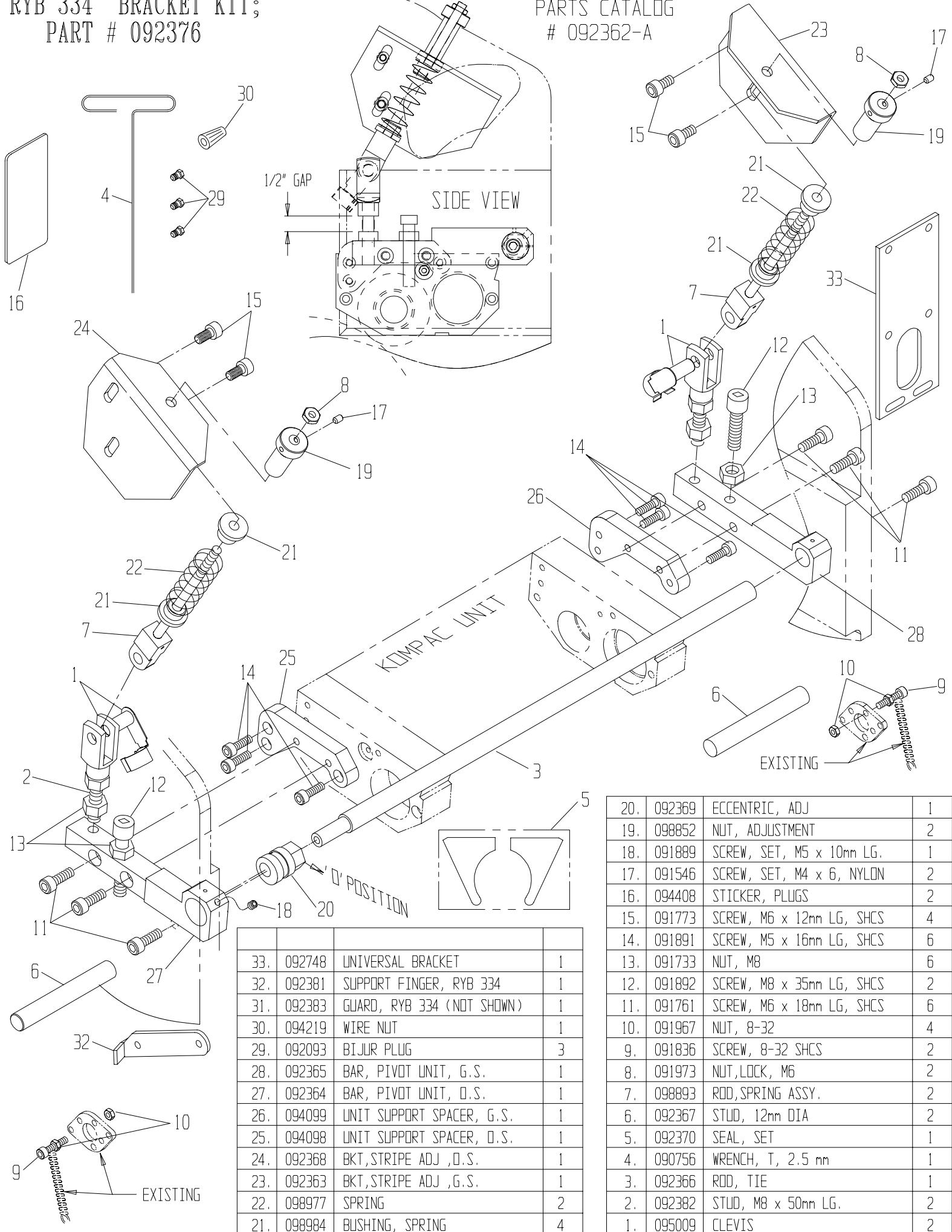

ITEM	PART #	DESCRIPTION	QTY.
33.	092748	UNIVERSAL BRACKET	1
32.	092381	SUPPORT FINGER, RYB 334	1
31.	092383	GUARD, RYB 334 (NOT SHOWN)	1
30.	094219	WIRE NUT	1
29.	092093	BIJUR PLUG	3
28.	092365	BAR, PIVOT UNIT, G.S.	1
27.	092364	BAR, PIVOT UNIT, D.S.	1
26.	094099	UNIT SUPPORT SPACER, G.S.	1
25.	094098	UNIT SUPPORT SPACER, D.S.	1
24.	092368	BKT, STRIPE ADJ ,D.S.	1
23.	092363	BKT, STRIPE ADJ ,G.S.	1
22.	098977	SPRING	2
21.	098984	BUSHING, SPRING	4

20.	092369	ECCENTRIC, ADJ	1
19.	098852	NUT, ADJUSTMENT	2
18.	091889	SCREW, SET, M5 x 10mm LG.	1
17.	091546	SCREW, SET, M4 x 6, NYLON	2
16.	094408	STICKER, PLUGS	2
15.	091773	SCREW, M6 x 12mm LG, SHCS	4
14.	091891	SCREW, M5 x 16mm LG, SHCS	6
13.	091733	NUT, M8	6
12.	091892	SCREW, M8 x 35mm LG, SHCS	2
11.	091761	SCREW, M6 x 18mm LG, SHCS	6
10.	091967	NUT, 8-32	4
9.	091836	SCREW, 8-32 SHCS	2
8.	091973	NUT, LOCK, M6	2
7.	098893	ROD, SPRING ASSY.	2
6.	092367	STUD, 12mm DIA	2
5.	092370	SEAL, SET	1
4.	090756	WRENCH, T, 2.5 mm	1
3.	092366	ROD, TIE	1
2.	092382	STUD, M8 x 50mm LG.	2
1.	095009	CLEVIS	2

ITEM	PART #	DESCRIPTION	QTY.
------	--------	-------------	------

# HOSE KIT R.R.M.: P/N 095924

**PRINTERS PARTS**  
 800-543-1117 201-935-9595  
 fax 800-392-4072 201-935-5333  
 www.ppsnj.com

PARTS CATALOG # 092362-A

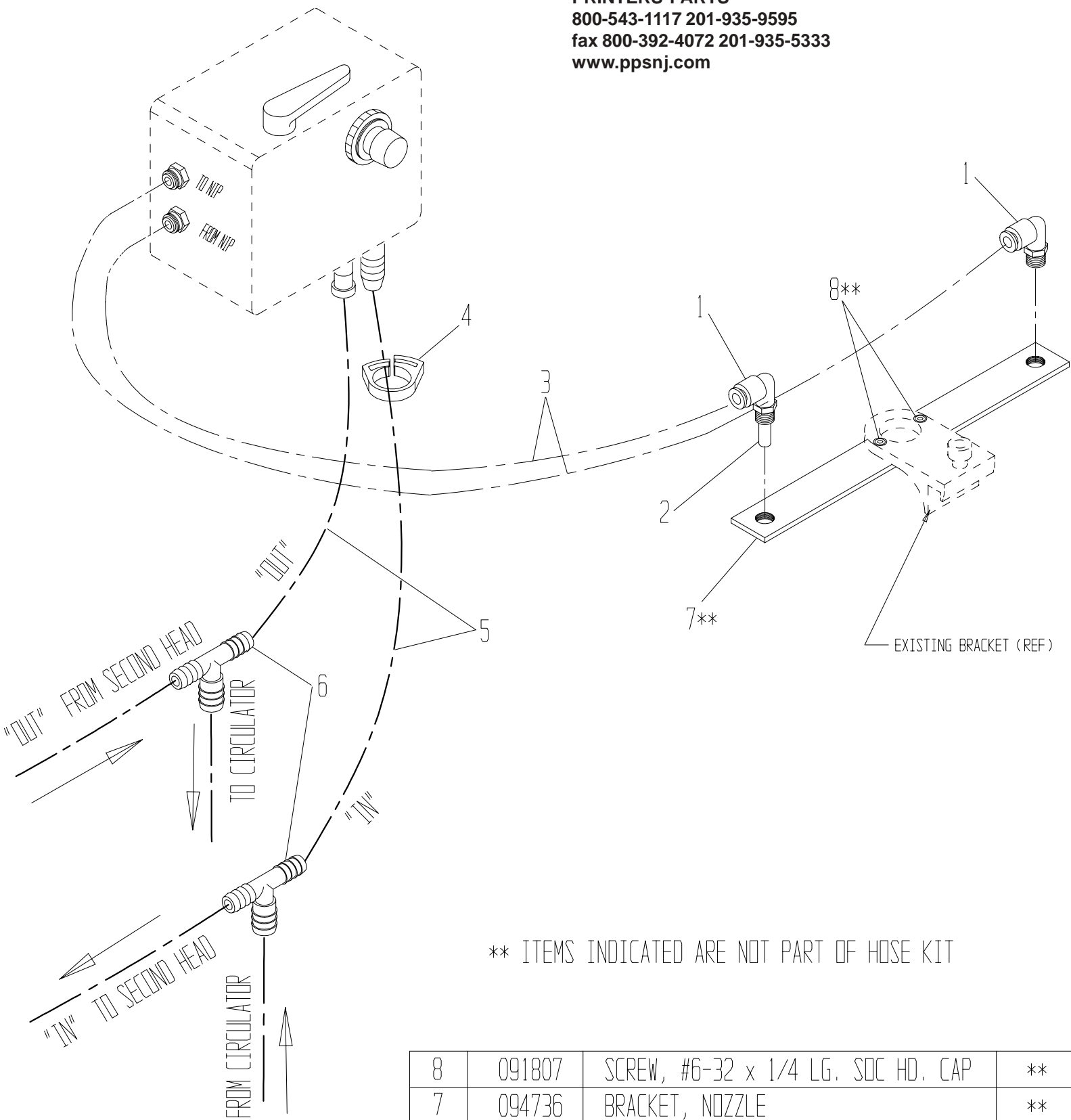

\*\* ITEMS INDICATED ARE NOT PART OF HOSE KIT

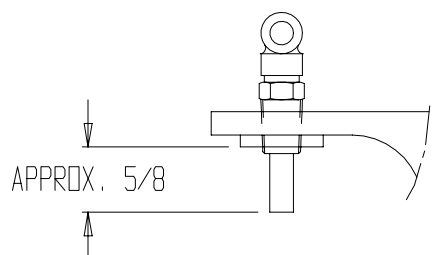

CUT TUBING ITEM #2 TO LENGTH  
 AT INSTALLATION

8	091807	SCREW, #6-32 x 1/4 LG. SOC HD. CAP	**
7	094736	BRACKET, NOZZLE	**
6	091077	BARB TEE 1/2 X 3/8 X 3/8	1
5	091081	PVC FLEX. TUBING 3/8 I.D. X 5/8 O.D.	1
4	091911	CLAMP, HOSE	8
3	091079	TUBING 1/4 O.D. X .170 I.D.(POLYETH)	1
2	091078	1/4 O.D. TUBING, 2" LG	1
1	094916	ELBOW	2
ITEM	PART NO.	DESCRIPTION	QTY.

# RECIRCULATOR SUBASS'Y: P/N 094730

PARTS CATALOG # 092362-A

**PRINTERS PARTS**  
 800-543-1117 201-935-9595  
 fax 800-392-4072 201-935-5333  
[www.ppsnj.com](http://www.ppsnj.com)

NOTE: USE THREAD SEALANT FELPRO #51370 OR EQUIVALENT ON ALL PIPE THREADED CONNECTIONS

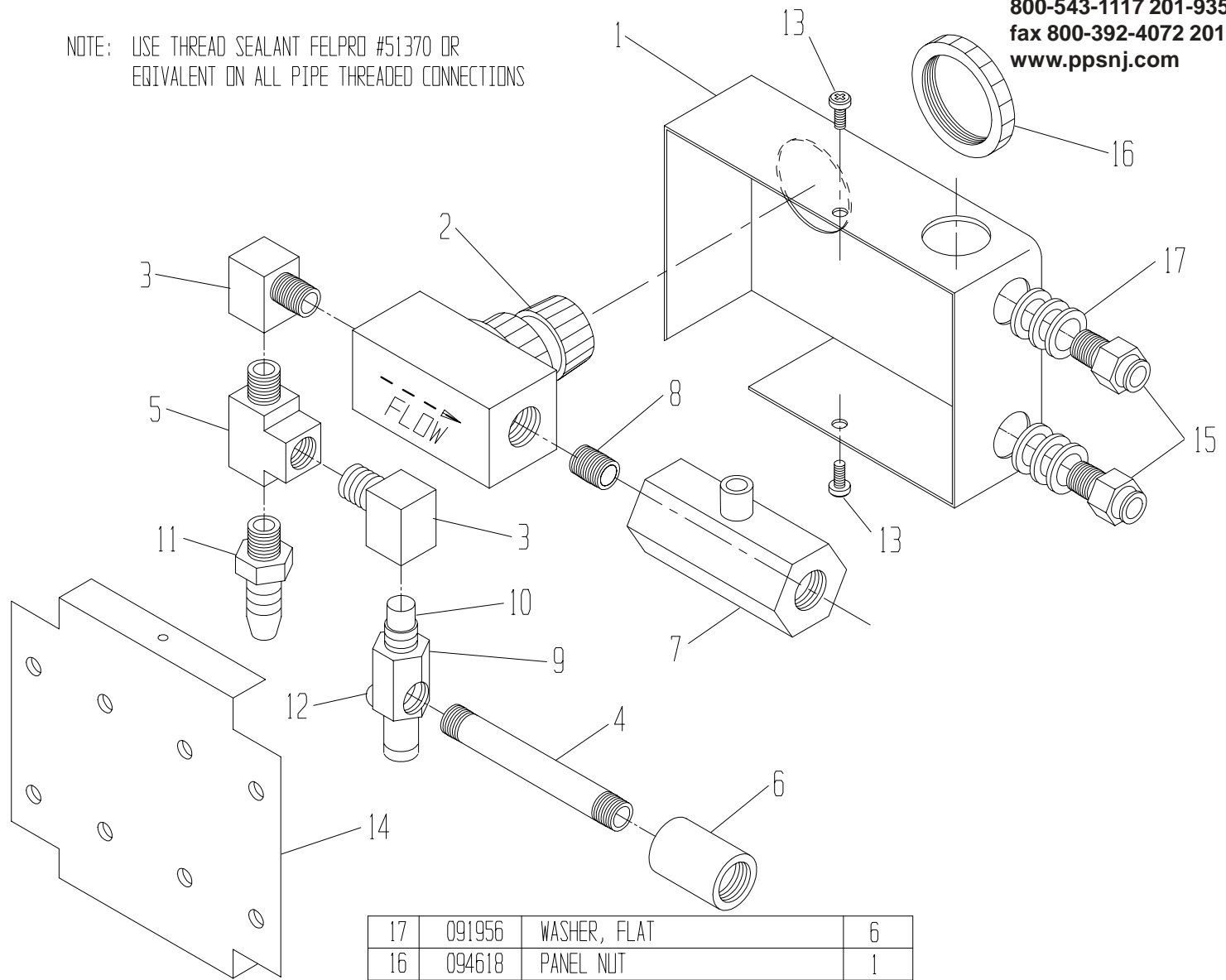

17	091956	WASHER, FLAT	6
16	094618	PANEL NUT	1
15	095955	CONNECTOR 1/8 NPT x 1/4 HOSE.	2
14	094612	PLATE, MOUNTING	1
13	091907	SCREW #6-32 PAN HD. SELF-TAP	2
12	091824	SCREW #6-32 TRUSS HD.	1
11	091062	FITTING, 1/8 NPT x 3/8 BARB	1
10	095939	TIP, VACUUM	1
09	095938	BODY, VACUUM	1
08	095948	NIPPLE, CLOSE, 1/8 NPT	1
07	095949	BALL VALVE	1
06	094616	COUPLING, 1/8 NPT	1
05	094613	TEE, STREET, 1/8 NPT	1
04	094615	NIPPLE, LONG, 1/8 NPT	1
03	094614	ELBOW, STREET, 1/8 NPT	2
02	094617	NEEDLE VALVE	1
01	094611	ENCLOSURE	1
ITEM	PART NO.	DESCRIPTION	QTY.