

Date of Installation : \_\_\_\_\_

Unit Serial Number : \_\_\_\_\_

Kompac Dealer : \_\_\_\_\_  
PRINTERS PARTS  
800-543-1117 201-935-9595  
fax 800-392-4072 201-935-5333  
www.ppsnj.com

***VARN***  
**Kompac<sup>®</sup>**

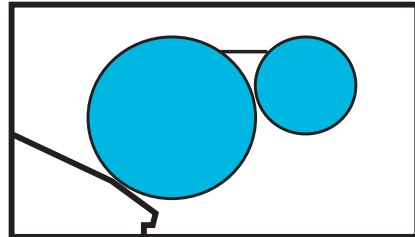

**MODEL : TK 47**  
PARTS CATALOG # 90312 REV.E

# TK 47 PARTS CATALOG

P/N 090312

**PRINTERS PARTS**

**800-543-1117 201-935-9595**

**fax 800-392-4072 201-935-5333**

**www.ppsnj.com**

REV	DESCRIPTION	ECN	BY	DATE
A	UPDATED TO NEW PARTS CATALOG FORMAT	1132	MJC	9-19-95
B	REPLACED P/N 091311 WITH 081311.	1207	MJC	7-9-96
C	ADDED SHAFT ASSY S.S. 091262	1252	BS	1-31-97
D	91117 WAS 91111	1280	BS	5-05-97
E	ITEM #5 WAS 081311	1411	ZZ	06-16-98

TK 47 UNIT: P/N 094210

TK 47-KM UNIT: P/N 094230

PRINTERS PARTS

800-543-1117 201-935-9595

fax 800-392-4072 201-935-5333

www.ppsnj.com

PARTS CATALOG #090312 REV E

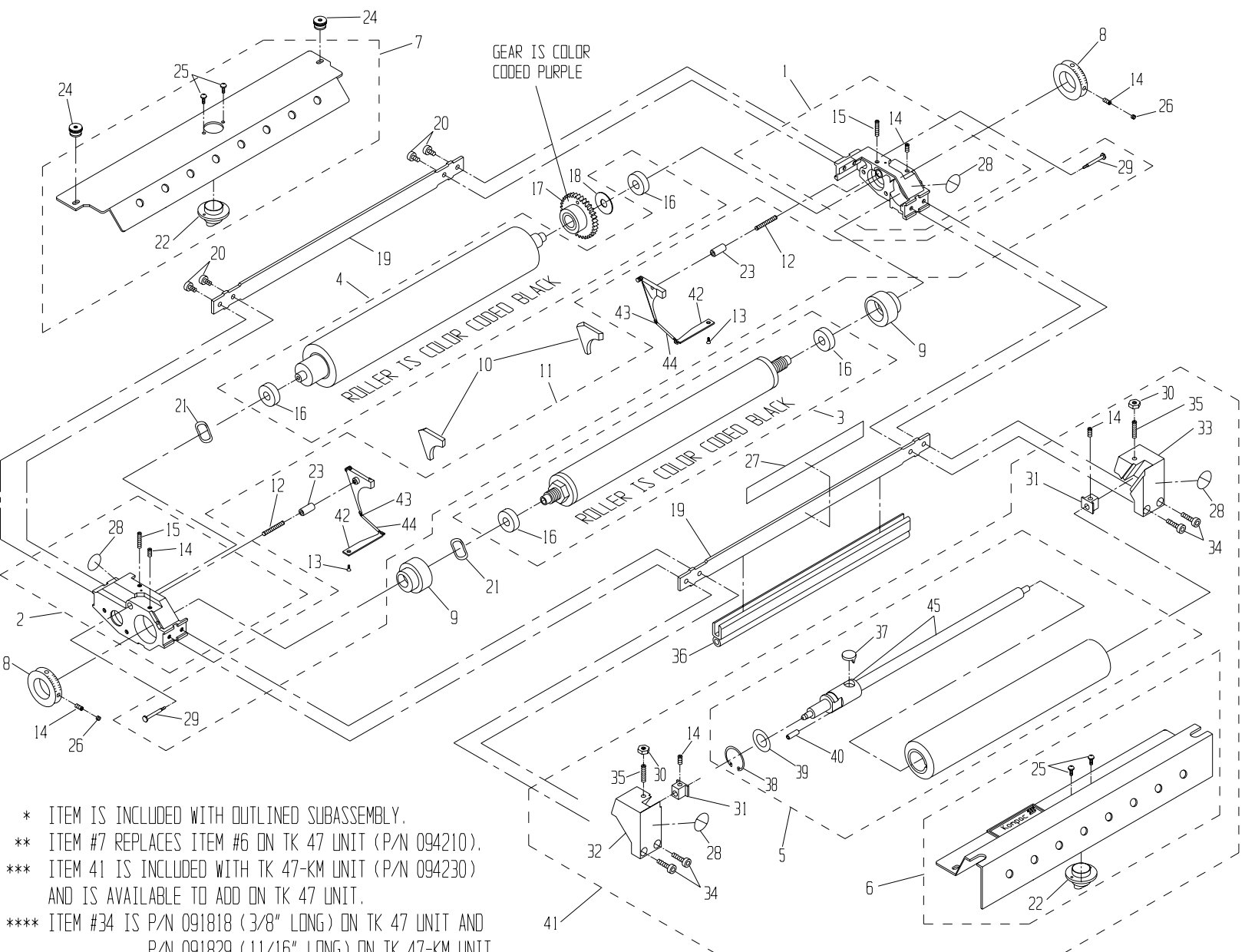

45	091262	SHAFT ASSY S.S.	*	30	091982	#10-32 NUT	2	15	091814	#10-24 X 3/4 SET SCREW	*
44	092259	SPRING COVER	*	29	092303	SHOULDER SCREW	*	14	091811	#10-24 X 1/4 SET SCREW	4 *
43	092236	TAB SPRING	*	28	092601	INWARD NIP SYMBOL	2*	13	091802	#3-48 X 1/4 FLAT HD SCREW	*
42	092234	TAB	*	27	092494	WARNING STICKER	1	12	092238	COMPRESSION SPRING	*
41	096580	KOLORMATE MODEL 90	***	26	091810	#10-24 X 1/8 SLOT SET SCW	2	11	092290	BACKING PLATE KIT (L & R)	1
40	091949	SPRING PIN	*	25	091806	#6-32 X 3/8 PHILLIPS HD SCW	*	10	092370	KOMPAC SEAL SET (L & R)	1
39	091965	WASHER	*	24	092691	COVER NUT	2	9	092291	ECCENTRIC	2
38	091997	RETAINING CLIP	*	23	092304	GUIDE PIN	*	8	092222	METERING GAUGE	2
37	091117	DRIVE SHAFT FOLLOWER	*	22	092604	NOZZLE	*	7	092620	13" COVER ASSEMBLY	1**
36	094216	PLATE GUARD	1	21	092491	WAVE WASHER	2	6	091360	13" COVER ASSY (OSC)	**
35	091851	#10-32 X 1 SET SCREW	2	20	091838	#10-24 X 3/8 HEX HD SCREW	4	5	091311	ASSY, 13-1/4" OSC., LONG S.	1
34	****	#10-24 SOCKET HEAD SCREW	4	19	094215	13-1/4" TIE BAR	2	4	094250	13-1/4" FORM ROLLER W/B	1
33	091017	R.H. OSC. END BLOCK	1	18	092415	THRUST WASHER	1	3	094240	13-1/4" METERING ROLLER W/B	1
32	091018	L.H. OSC. END BLOCK	1	17	092920	GEAR CLUTCH ASSY, TK 47	1	2	092210	L.H. END FRAME ASSY	1
31	091219	ALIGNMENT BLOCK	2	16	092401	BEARING	*	1	092200	R.H. END FRAME ASSY	1

ITEM#	PART #	DESCRIPTION	QTY	ITEM#	PART #	DESCRIPTION	QTY	ITEM#	PART #	DESCRIPTION	QTY
-------	--------	-------------	-----	-------	--------	-------------	-----	-------	--------	-------------	-----

# TK 47 BRACKET KIT: P/N 094220

**PRINTERS PARTS**  
**800-543-1117 201-935-9595**  
**fax 800-392-4072 201-935-5333**  
**www.ppsnj.com**

PARTS CATALOG #090312 REV E

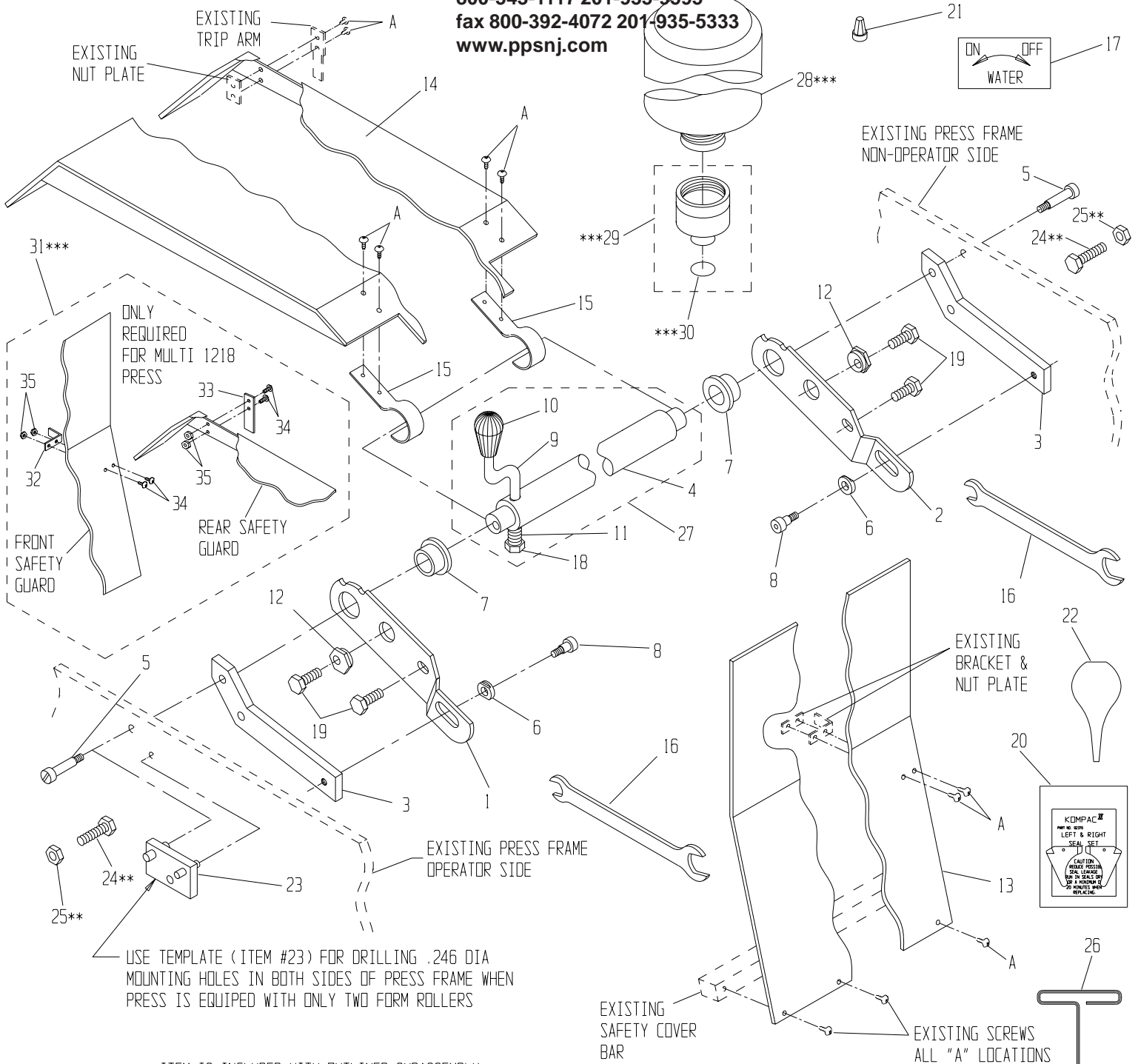

- \* ITEM IS INCLUDED WITH OUTLINED SUBASSEMBLY.
- \*\* ITEM IS USED ONLY WHEN THIRD FORM ROLLER IS NOT ON PRESS.
- \*\*\* ITEMS 28, 29, 30, & 31 ARE NOT INCLUDED WITH BRACKET KIT (P/N 094220).

ITEM	PART NO.	DESCRIPTION	QTY.
35	91964	6-32 NUT	*
34	91822	6-32x3/8 PHILLIPS PAN HEAD SCW	*
33	94289	INK GUARD TRIP ARM	*
32	94288	PLATE GUARD TRIP ARM	*
31	94290	SAFETY COVER TRIP ARM ASSY	***
30	92765	O-RING	*
29	92760	DISPENSING VALVE ASSY	***
28	92771	CALIBRATED BOTTLE	***
27	94260	TIE ROD ASSY	1
26	90755	3/32 HEX T-WRENCH	1
25	91972	1/4-20 LOCK NUT	2
24	91869	1/4-20x1 HEX HEAD SCREW	2
23	94218	DRILL TEMPLATE	1
22	92778	KOMPAC SYRINGE	1
21	94219	WIRE NUT	1
20	92370	KOMPAC SEAL SET	1
19	91867	1/4-20x1/2 HEX HEAD SCREW	4
ITEM	PART NO.	DESCRIPTION	QTY.

18	91971	1/4-28 LOCK NUT	*
17	94222	ON/OFF DECAL	1
16	93555	KOMPAC WRENCH	2
15	94224	HINGE BRACKET	2
14	94225	FRONT SAFETY GUARD	1
13	94226	REAR SAFETY GUARD	1
12	93543	BRACKET ECCENTRIC	2
11	94227	COMPRESSION SPRING	*
10	94228	KNOB	*
9	94229	ARM	*
8	94231	1/4x1/4 SOCKET HD SHOULDER SCW	2
7	92054	FLANGE BEARING	2
6	94232	SHOULDER BEARING	2
5	94233	SLOT HEAD SHOULDER SCREW	2
4	94234	TIE ROD	*
3	94237	SUPPORT BRACKET	2
2	94235	NON-OP SIDE INSIDE BRACKET	1
1	94236	OP-SIDE INSIDE BRACKET	1
ITEM	PART NO.	DESCRIPTION	QTY.